

BABY BOVINES



MUMM'S™  
THE WORD

(509) 482-0210

Fax: 509-482-2036

# BABY BOVINES *by Debbie Mumm*

QP-55

Newborn calves in the farmyard are gentle reminders of spring in the country. Bring their wide-eyed innocence into your home with this charming four-block quilt and matching pillows. The template-free, quick-sew techniques make it fun and easy to create these baby bovines that will never grow up.

**Fabric Requirements** (Directional fabrics are not recommended)

## **Four-Block Quilt 27" x 25"**

**Fabric A** (Calf) - 1/8 yard EACH of four fabrics

**Fabric B** (Background)- Blocks & Four-patches (first color) - 1/4 yard

**Fabric C** (Face) - 1/8 yard (OR one 3 1/2" x 10" strip) EACH of four fabrics

**Fabric D** (Bell) - 1/8 yard (OR one 2 1/2" x 3 1/2" piece) EACH of four fabrics

**Lattice** - 1/4 yard

**Four-patches** (second color) - 1/8 yard (OR one 1 1/2" x 30" strip)

**Binding** - 1/3 yard

**Backing & Lightweight Batting** - 7/8 yard each

Eight 3/4" buttons for eyes, eight 7/16" buttons for nostrils and  
four 5/8" buttons for cow bells

## **Pillow 15" x 14"**

**To make one pillow:**

**Fabric A** (Calf) - 1/8 yard

**Fabric B** (Background) Blocks & Four-patches (first color) - 1/8 yard

**Fabric C** (Face) - 1/8 yard (OR one 3 1/2" x 10" strip)

**Fabric D** (Bell) - 1/8 yard (OR one 2 1/2" x 3 1/2" piece)

**Border** - 1/8 yard

**Four-patches** (second color) - 1/8 yard (OR one 1 1/2" x 14" strip)

**Binding** - 1/8 yard

**Lining & Lightweight Batting** - 1/2 yard each

**Backing** - 1/3 yard

Two 3/4" buttons for eyes, two 7/16" buttons for nostrils and  
one 5/8" button for cow bell

1 lb. bag of Fiberfil pillow stuffing



©1994 Mumm's The Word®, Inc.  
1116 E. Westview Ct.  
Spokane WA 99218-1384  
(509)466-3572

All rights reserved. No part of this pattern may be photocopied or reproduced without written consent of Mumm's The Word®, Inc. All finished items produced from this pattern are protected by Federal Copyright Laws and may not be reproduced for commercial use in any form whatsoever without the express written consent of Mumm's The Word®, Inc.



# BABY BOVINES

Newborn calves in the farmyard are gentle reminders of spring in the country. Bring their wide-eyed innocence into your home with this charming four-block quilt and matching pillows. The template-free, quick-sew techniques make it fun and easy to create these baby bovines that will never grow up. Remember to read all instructions before beginning and use 1/4" seams throughout.

## FOUR-BLOCK QUILT

Finished Size: 27" x 25"

Finished Block Size: 10" x 9"

### CUTTING THE STRIPS AND PIECES

Pre-wash and press fabrics. Using a rotary cutter and see-through ruler, cut the following strips and pieces. If indicated, some strips will need to be cut again into smaller strips or pieces. 44" is the approximate width of the fabric. Measurements for all pieces include 1/4" seam allowance.

**Fabric A (Calf)** - One 3 1/2" x 44" strip, cut into

- One 3 1/2" x 6" piece
- One 3 1/2" x 1 1/2" piece
- Two 2 1/2" squares
- One 1 1/2" x 9 1/2" piece
- One 1 1/2" x 6 1/2" piece
- Eight 1 1/2" squares

Repeat for EACH of four fabrics

**Fabric B (Background)**

**Blocks** - One 2 1/2" x 44" strip, cut into

- Four 2 1/2" x 6 1/2" pieces
- Four 2 1/2" x 1" pieces
- Two 1 1/2" x 44" strips, cut into
- Four 1 1/2" x 4" pieces
- Eight 1 1/2" x 2 1/2" pieces
- Thirty-two 1 1/2" squares

**Four-patches (first color)** - One 1 1/2" x 30" strip

**Fabric C (Face)**

- One 3 1/2" x 4 1/2" piece and one 3 1/2" square
- Repeat for EACH of four fabrics

**Fabric D (Bell)** - One 2 1/2" x 3 1/2" piece

Repeat for EACH of four fabrics

**Lattice** - Three 2 1/2" x 44" strips, cut into

- Six 2 1/2" x 9 1/2" strips and six 2 1/2" x 10 1/2" strips

**Four-patches (second color)** - One 1 1/2" x 30" strip

**Binding** - Four 2 3/4" x 44" strips

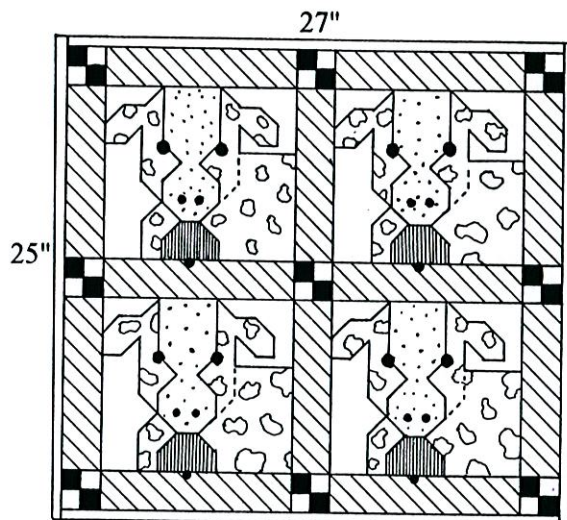

QUILT LAYOUT

## QUICK CORNER TRIANGLES

Quick corner triangles are formed by simply sewing fabric squares to other squares and rectangles. Follow steps 1 - 3 below to make corner triangles.

### BASIC DIRECTIONS

1. With a pencil, draw a diagonal line from corner to corner on the wrong side of fabric square that will form the triangle. This will be your sewing line. See Diagram A.
2. With right sides together, place the square on the corresponding piece. Matching raw edges, pin in place and sew ON the drawn diagonal line.
3. Trim off excess fabric, leaving a 1/4" seam allowance. See Diagram B. Press all seams toward the triangle, except when otherwise indicated. HINT: For greater accuracy, I suggest trimming away the excess after you have done the pressing.

(As many as four corner triangles may be sewn to one piece of fabric.)

The directions and diagrams on page 2 show you what size pieces to use, where to mark the diagonal sewing line and where to place the square on the corresponding piece. See Fabric Key on page 2 for fabric identification. Follow directions carefully, and be sure to measure each piece after adding the corner triangle.

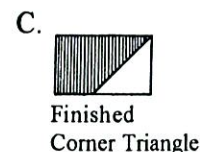
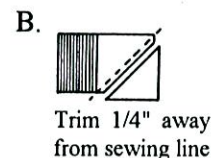
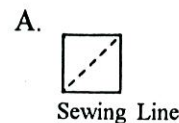

## QUICK CORNER TRIANGLES cont.

You will be making four blocks, one each of four fabric combinations. Before you start sewing, coordinate the fabrics for each of the four combinations. Keep track of the combinations as you sew. For each step below, use the following "assembly-line" method to make enough of the same corner triangle pieces for all four blocks. For each step, position pieces right sides together and line up all sets next to your sewing machine. Stitch the first set together, then continue sewing the second set without breaking your thread. Sew all four sets for this step. Cut threads, trim and press in the direction indicated by the arrow in each diagram.

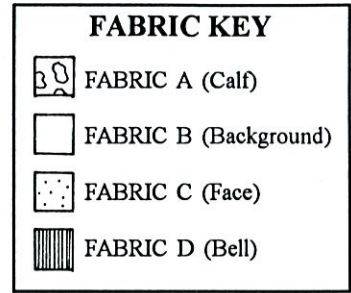

- 1a. Sew eight 1 1/2" Fabric B squares to eight 2 1/2" Fabric A squares (two each of four different Fabric A's). Press.
- 1b. Sew eight additional 1 1/2" Fabric B squares to eight units from step 1a. Press.
- 2a. Sew four 1 1/2" Fabric B squares to four 1 1/2" x 6 1/2" Fabric A pieces. Press.
- 2b. Sew four additional 1 1/2" Fabric B squares to four units from step 2a. Press.
3. Sew four 1 1/2" Fabric B squares to four 1 1/2" x 3 1/2" Fabric A pieces. Press seams toward Fabric A.
- 4a. Sew four 1 1/2" Fabric A squares to four 3 1/2" x 4 1/2" Fabric C pieces. Press seams toward Fabric C.
- 4b. Sew four additional 1 1/2" Fabric A squares to four units from step 4a. Press seams toward Fabric C.
- 5a. Sew four 1 1/2" Fabric A squares to four 3 1/2" Fabric C squares. Press.
- 5b. Sew four additional 1 1/2" Fabric A squares to four units from step 5a. Press.
- 5c. Sew four additional 1 1/2" Fabric A squares to four units from step 5b. Press.
- 5d. Sew four additional 1 1/2" Fabric A squares to four units from step 5c. Press.
- 6a. Sew four 1 1/2" Fabric A squares to four 3 1/2" x 2 1/2" Fabric D pieces. Press seams toward Fabric D.
- 6b. Sew four additional 1 1/2" Fabric A squares to four units from step 6a. Press seams toward Fabric D.
7. Sew four 1 1/2" Fabric B squares to four 1 1/2" x 9 1/2" Fabric A pieces. Press.

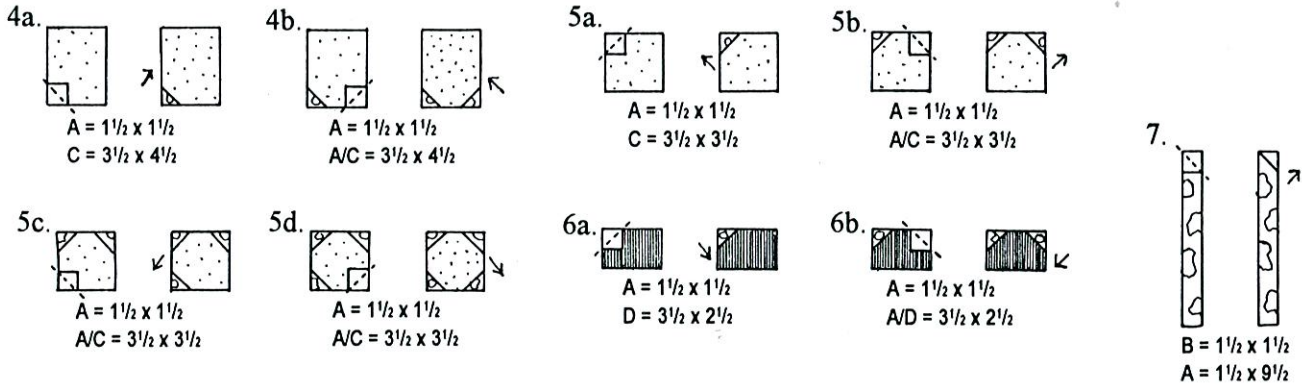
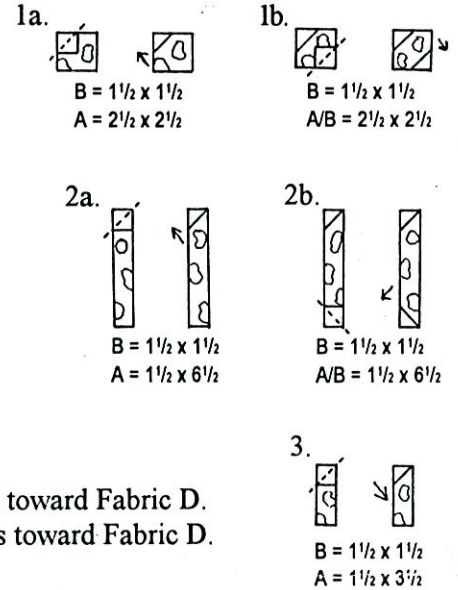

## PIECING THE BLOCKS

You will be making a total of four blocks. Repeat the same step for each block at the same time. This "assembly-line" method will speed up the piecing process. Pay close attention that the corner triangles are positioned the same as shown in the diagrams. Press seams after each sewing step, following direction of arrows in diagrams. Refer to diagram for each step.

**HINT:** It may be helpful to lay out the pieces that will make up one block to help you visualize how they go together.

1. Sew four 2 1/2" x 1 1/2" Fabric B pieces to four 2 1/2" x 2 1/2" Fabric A/B corner triangle units. Position pieces right sides together and line up next to your sewing machine. Stitch the first set together, then butt the same set from the second block directly behind and continue sewing the second set without breaking your seam. Sew all four sets. Cut threads, press. Using this same "assembly-line" method, complete the following steps.
2. Sew four units from step 1 to four 2 1/2" x 6 1/2" Fabric B pieces. Press.

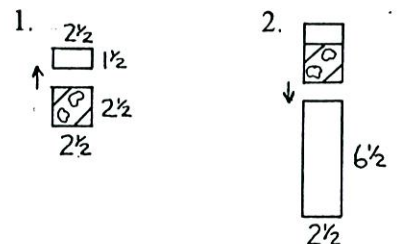

### PIECING THE BLOCKS cont.

3. Sew four 1 1/2" x 6 1/2" Fabric A/B corner triangle units to four 1 1/2" x 3 1/2" Fabric A/B corner triangle units. Press.
4. Sew four 3 1/2" x 4 1/2" Fabric A/C corner triangle units to four 3 1/2" x 3 1/2" Fabric A/C corner triangle units. Press.
5. Sew four 3 1/2" x 2 1/2" Fabric A/D corner triangle units to four units from step 4. Press.
6. Sew four 2 1/2" x 1 1/2" Fabric B pieces to four 2 1/2" x 2 1/2" Fabric A/B corner triangle units. Be sure to refer to diagram for proper position of the corner triangle units. Press.
7. Sew four units from step 6 to four 2 1/2" x 1" Fabric B pieces. Press.
8. Sew four units from step 7 to four 1 1/2" x 4" Fabric B pieces. Press.
9. Sew four units from step 8 to four 3 1/2" x 6" Fabric A pieces. Press.
10. Sew four units from step 2 to four units from step 3. Press.
11. Sew four units from step 10 to four units from step 5. Press.
12. Sew four units from step 11 to four 1 1/2" x 9 1/2" Fabric A/B corner triangle units. Press.
13. Sew four units from step 12 to four units from step 9. Press.

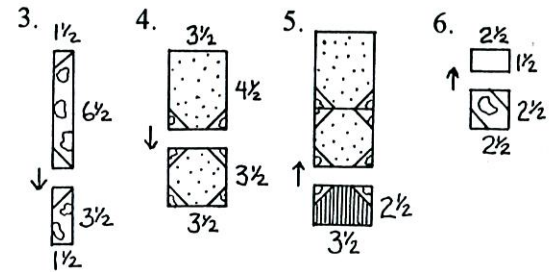
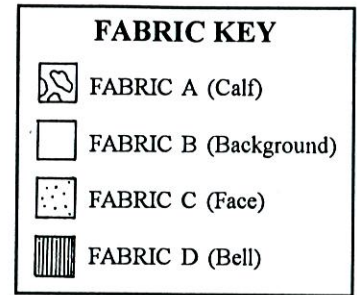

Blocks will measure 10 1/2" x 9 1/2"

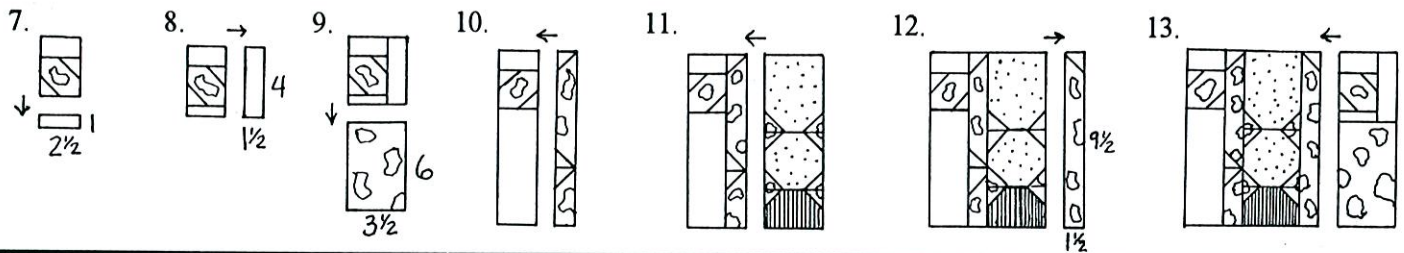

### THE LATTICE & FOUR-PATCHES

1. Lay out your blocks in a pleasing arrangement. Keep track of your layout while sewing on the lattice.
2. Sew 2 1/2" x 9 1/2" lattice strips between the two blocks in the top row. Press all seams toward lattice. Sew 2 1/2" x 9 1/2" lattice strips to each end of the row. Press. See Diagram D. Repeat for bottom row.
3. Sew the two 1 1/2" x 30" four-patch strips together. Press seam toward darker fabric. See Diagram E.
4. Using rotary cutter and ruler, cut eighteen 2 1/2" x 1 1/2" pieces from the strip set. See Diagram F.
5. Sew the pieces together in pairs to make nine 2 1/2" x 2 1/2" four-patch units. See Diagram G.
6. To assemble horizontal lattice strips, sew a 2 1/2" x 2 1/2" four-patch between two 2 1/2" x 10 1/2" lattice strips. Press seams toward lattice. Sew a four-patch to each end of lattice strip. See Diagram H. Press. Repeat to make three horizontal lattice strips.
7. Fit, pin, and sew lattice strips to the top of both rows of blocks and to the bottom of the bottom row. Press seams toward lattice. Join rows. Press.

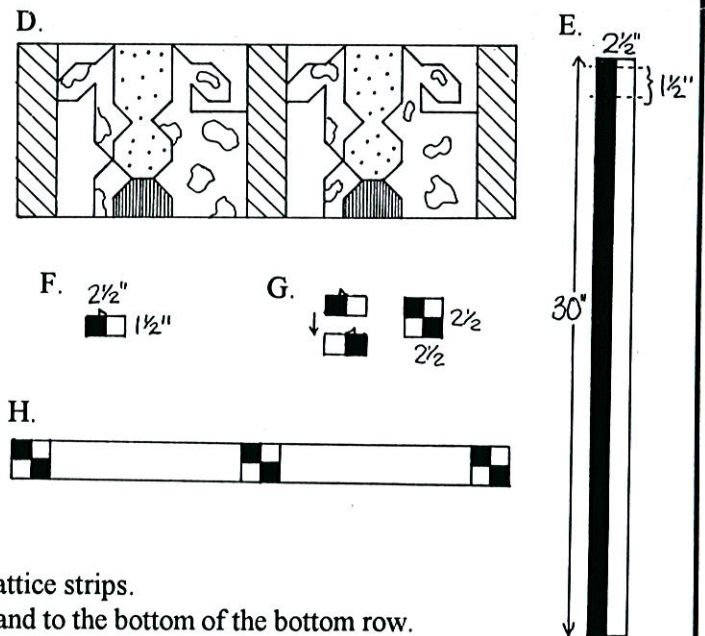

### LAYERING THE QUILT

1. Cut the backing and batting pieces 4" to 6" larger than the quilt top.
2. Lay the pressed backing on the bottom (right side down), batting in the middle and pressed quilt top on top. Make sure everything is centered and that backing and batting are flat. Backing and batting should extend 2" to 3" beyond quilt top.
3. Begin basting in center and work out to the outer edges. Baste vertically and horizontally forming about a 3" to 4" grid. Next, baste or pin completely around the edge of the quilt top. Last, trim batting and backing to 1/4" from raw edge of quilt top.

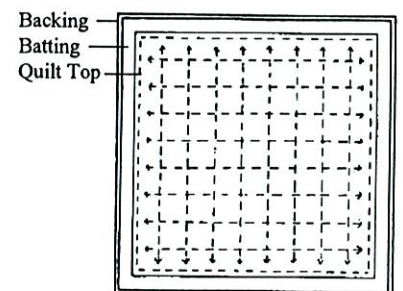

## BINDING THE QUILT

1. Press four  $2\frac{3}{4}$ " x 44" binding strips in half with wrong sides together.
2. Align raw edges of binding with the edge of the quilt top and bottom. Sew  $\frac{1}{4}$ " from quilt edge, going through all layers of the quilt. Trim excess and press toward binding.
3. Sew binding strips to quilt sides. Trim excess and press.
4. Bring binding around to back, folding in corners. Fold in the top and bottom bindings first (with raw edges showing).
5. Press and pin in position. Handstitch in place.

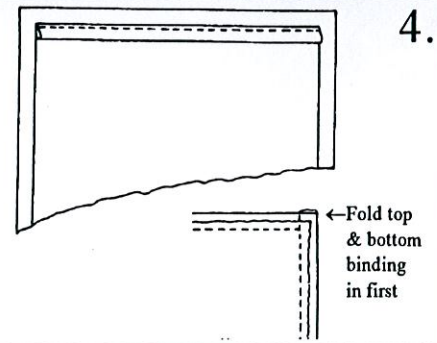

## THE FINISHING TOUCHES

Machine or hand quilt in the seam line around each calf, bell and face. Quilt in the seam line around the lattice and between the squares of the four patches. Quilt a  $1\frac{1}{4}$ " diagonal grid in the lattice and 1" horizontal lines in the block background. Refer to Diagram I to quilt an outline of the shape of the head and "splotches" on the bodies. Sew two  $\frac{3}{4}$ " buttons for eyes, two  $\frac{7}{16}$ " buttons for nostrils and one  $\frac{5}{8}$ " button for a cow bell to each baby bovine.

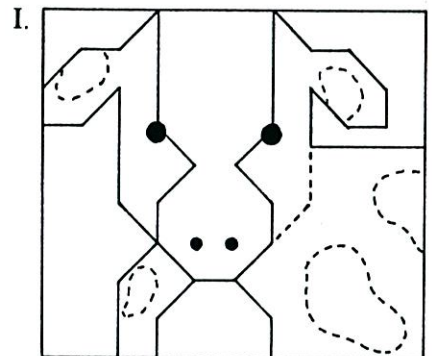

## BABY BOVINE PILLOW

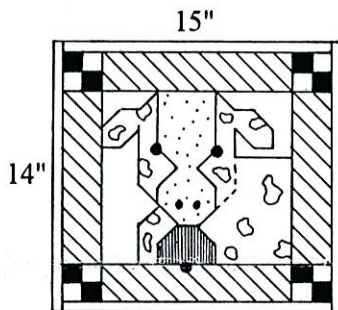

PILLOW LAYOUT

Finished Size: 15" x 14"  
Finished Block Size: 10" x 9"

### CUTTING THE STRIPS AND PIECES

Pre-wash and press fabrics. Using a rotary cutter and see-through ruler, cut the following strips and pieces. If indicated, some strips will need to be cut again into smaller strips or pieces. 44" is the approximate width of the fabric. Measurements for all pieces include  $\frac{1}{4}$ " seam allowance.

**Fabric A (Calf)** - One  $3\frac{1}{2}$ " x 44" strip, cut into

- One  $3\frac{1}{2}$ " x 6" piece
- One  $3\frac{1}{2}$ " x  $1\frac{1}{2}$ " piece
- Two  $2\frac{1}{2}$ " squares
- One  $1\frac{1}{2}$ " x  $9\frac{1}{2}$ " piece
- One  $1\frac{1}{2}$ " x  $6\frac{1}{2}$ " piece
- Eight  $1\frac{1}{2}$ " squares

**Fabric B (Background)** - One  $2\frac{1}{2}$ " x 44" strip, cut into

- Blocks** - One  $2\frac{1}{2}$ " x  $6\frac{1}{2}$ " piece
- One  $2\frac{1}{2}$ " x 1" piece
  - Two  $2\frac{1}{2}$ " x  $1\frac{1}{2}$ " pieces
  - One  $1\frac{1}{2}$ " x 4" piece
  - Eight  $1\frac{1}{2}$ " squares

**Four-patches (first color)** - One  $1\frac{1}{2}$ " x 14" strip

**Fabric C (Face)**

- One  $3\frac{1}{2}$ " x  $4\frac{1}{2}$ " piece and one  $3\frac{1}{2}$ " square

**Fabric D (Bell)** - One  $2\frac{1}{2}$ " x  $3\frac{1}{2}$ " piece

**Border** - One  $2\frac{1}{2}$ " x 44" strip, cut into

- Two  $2\frac{1}{2}$ " x  $9\frac{1}{2}$ " pieces and two  $2\frac{1}{2}$ " x  $10\frac{1}{2}$ " pieces

**Four-patches (second color)**

- One  $1\frac{1}{2}$ " x 14" strip

**Binding** - Two 1" x 44" strips, cut into

- Four 1" x  $14\frac{1}{2}$ " strips

**Backing** - Two  $9\frac{1}{4}$ " x  $14\frac{1}{2}$ " pieces

## QUICK CORNER TRIANGLES

Read through QUICK CORNER TRIANGLES and BASIC DIRECTIONS on page 1. Follow sewing steps and diagrams 1a-7 on page 2. Instead of making four corner triangle units for each step, you will make only one.

## PIECING THE BLOCK

Read through PIECING THE BLOCKS for the four-block quilt on page 2. Follow sewing steps and diagrams 1-13 on pages 2 and 3 to piece one block.

## BORDER, FOUR-PATCHES & BINDING

1. Sew one  $2\frac{1}{2}$ " x  $10\frac{1}{2}$ " border strip to top and bottom of block. Press all seams toward border.
2. Sew the two  $1\frac{1}{2}$ " x 14" four-patch strips together. Press seam toward the darker fabric. See Diagram J.
3. Using rotary cutter and ruler, cut eight  $2\frac{1}{2}$ " x  $1\frac{1}{2}$ " pieces from the strip set. See Diagram K.
4. Sew the pieces together in pairs to make four  $2\frac{1}{2}$ " x  $2\frac{1}{2}$ " four-patch units. See Diagram L.
5. Sew one four-patch corner square to each end of the two remaining  $2\frac{1}{2}$ " x  $9\frac{1}{2}$ " border strips. Press seams toward border strips. Pin and sew border strips to side of blocks.
6. Sew 1" x  $14\frac{1}{2}$ " binding strips to top and bottom of block. Press all seams toward binding.
7. Sew 1" x  $14\frac{1}{2}$ " binding strips to sides. Press.

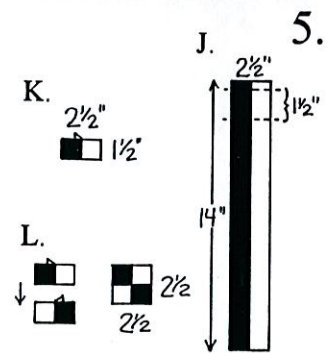

5.

## LAYERING THE PILLOW TOP

Arrange and baste the lining, batting, and pillow top together following directions for LAYERING THE QUILT on page 3.

## THE FINISHING STITCHES

Machine or hand quilt in the seam line around the calf, bell, face and between the squares of the four-patches. Quilt in the seam line between the border and the block. **Do not quilt in the seam line next to the binding.** Quilt a  $1\frac{1}{4}$ " diagonal grid in the border and 1" horizontal lines in the block background. Refer to Diagram I on page 4 to quilt an outline of the shape of the head and "splotches" on the bodies. Sew two  $\frac{3}{4}$ " buttons for eyes, two  $\frac{7}{16}$ " buttons for nostrils and one  $\frac{5}{8}$ " button for cow bell to the baby bovine.

## MAKING THE PILLOW BACK

1. On one long edge of a  $9\frac{1}{4}$ " x  $14\frac{1}{2}$ " pillow back piece, fold under  $\frac{1}{4}$ " to wrong side. Press. Fold again  $\frac{1}{2}$ " to wrong side. Press. Top stitch along folded edge to make hem. Repeat for second pillow back piece.
2. With right sides up, lap one pillow back piece over the second piece. The hemmed edges will overlap 3". Baste the pieces together at top and bottom where they overlap. See Diagram M. The pillow back now measures  $15\frac{1}{2}$ " x  $14\frac{1}{2}$ ".

## FINISHING THE PILLOW

1. With right sides together, sew the quilted pillow front to the back, using a  $\frac{1}{4}$ " seam allowance. Trim batting and lining even with the edges of the pillow top and backing. Trim corners, turn right sides out and press.
2. To create the look of cording, machine stitch in the seam line between the binding and the border.
3. To make a custom-fit pillow form, cut two pieces of batting or needlepunch  $14\frac{1}{2}$ " x  $13\frac{1}{2}$ ". Using a  $\frac{1}{4}$ " seam allowance, sew the two pieces of batting together, leaving a 3" to 4" opening for turning. Turn so the seam allowances are on the inside.
4. Fill the pillow form with stuffing until it reaches the desired firmness. Handstitch the opening closed. Slip the custom-made pillow form into the opening of your pillow.

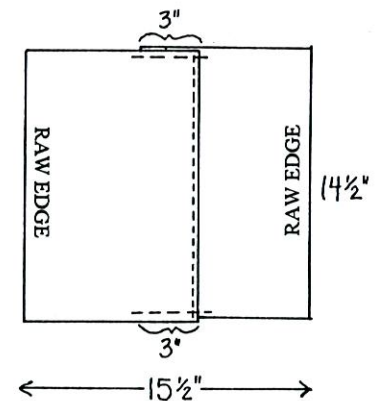

©1994 Mumm's The Word, Inc.  
All Rights Reserved

### Credits:

Designed by Debbie Mumm  
Projects by Kelly Fisher & Jodi Gosse  
Quilting by Mairi Fischer  
Photography by Robert Barros  
Cover Design by Marcia Smith Design

**NOTE:** We have made every attempt to make all the instructions clear, concise and correct. We present the quick cutting and sewing methods that we feel are most appropriate for you to quickly and successfully complete these projects. We realize other techniques will also achieve the same results.