

MONOGRAMMING

SETTINGS

Special Stitch Selector Dial - Zigzag
Stitch Position
Stitch Width Control - 1 to 2 *
Stitch Length Control - 0
Pressure Regulator - 0 (Release)
Feed Dogs - Up
Use zig zag needle plate.

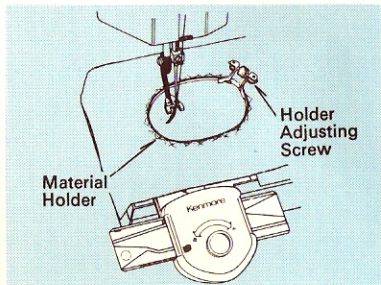
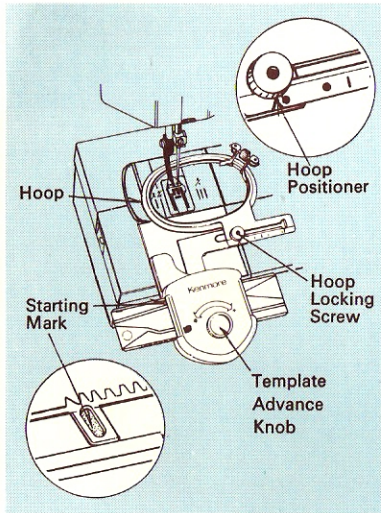
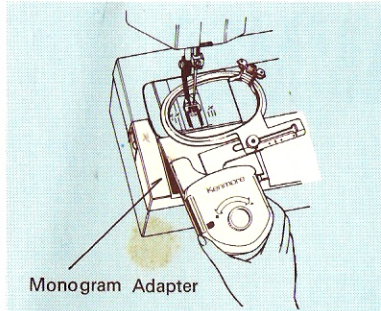

1. Raise needle to its highest point and raise presser foot.
2. Replace the presser foot with Monogram Foot.
3. Remove the front cover from the base. Open shuttle cover and replace with Monogram (Buttonhole) Adapter. Lift and hold presser foot lever beyond the normal up position. Snap monogrammer into position.
4. Select template with desired letter. Large or small letter size is selected by reversing template. Insert template into the monogrammer.
5. Turn the Template Advance Knob clockwise until the starting mark engraved on the template comes in alignment with left edge of the monogrammer.
6. To sew the first letter, set the Hoop Positioner in alignment with the extreme left line for 3/4" letters or the extreme left dot for 3/8" letters. Tighten the Hoop Locking Screw.
7. Turn Holder Adjusting Screw and remove Material Holder from the hoop. Place the material on the hoop (See "HELPFUL HINTS FOR MONOGRAMMING" on next page for letter alignment on material). Then insert the Material Holder into the hoop and turn Holder Adjusting Screw to hold the material tight without any slack. Lower the Monogram Foot, making sure both threads are pulled towards back.
- *8. Stitch width control
Control setting is 1 for small size and 2 for large size. You may need to increase or decrease stitch width slightly by turning the Stitch Width Control to suit your fabric.
9. Stop the machine as soon as the letter is completed. Remove the template by pulling it to the right. Raise the presser foot.
10. Loosen the Hoop Locking Screw and move the hoop, until the Hoop Positioner comes in alignment with the next graduation. Tighten the Hoop Locking Screw. Follow step 4 and 5. Lower the presser foot and continue to sew.

HELPFUL HINTS FOR MONOGRAMMING

1. Letter alignment on the material
Mark the cross lines on your garment and align the lines to raised mark on the hoop, and three large letters (3/4" square) or four small letters (3/8" square) will be horizontally aligned as shown below.

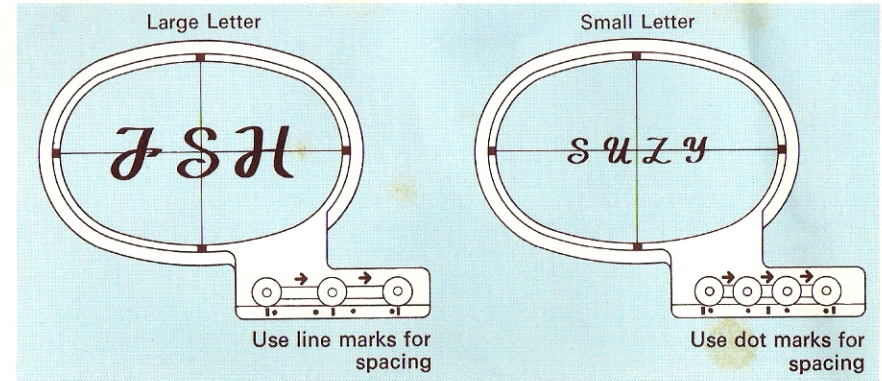

2. Thread tension control
It is necessary to reduce the upper thread tension somewhat when sewing monograms. The wider the stitch, the less tension is needed. It is not desirable to have any of the bottom thread visible on the right side of the fabric.
3. Needle size and thread
For better monogramming, use #9 or #11 needle and fine thread. Be sure to start with a well filled bobbin and plenty of thread on the spool as you would not want to run out of thread in the middle of a letter.
4. If you are planning to monogram a garment you are making, be sure to stitch your letters at an early stage of garment construction. It is much easier to work with a small piece of fabric before you sew the garment together.
5. Lightweight knits and woven materials must be backed with an interfacing.

NOTE - If the upper thread breaks during monogramming:

1. Stop the machine, and rethread the needle.
2. Pull and hold the Template Release Lever to the left of the machine with left hand and turn the Template Advance Knob counter-clockwise with right hand to return the material to the location where the machine stopped sewing.
3. Then continue to sew.

